

---

# User Manual

SG2KTL-S / SG3KTL-S / SG3KTL-D / SG5KTL-D

## PV Grid-Connected Inverter





# About This Manual

The manual mainly describes the product information, guidelines for installation, operation and maintenance. The manual cannot include complete information about the photovoltaic (PV) system. You can get additional information about other devices at [www.sungrowpower.com](http://www.sungrowpower.com) or on the webpage of the device manufacturer.

## Applicability

This manual is applicable to the following inverter types:

- SG2KTL-S
- SG3KTL-S
- SG3KTL-D
- SG5KTL-D

They will be referred to as “inverter” hereinafter unless otherwise specified.

## Target Group

This manual is intended for:

- qualified personnel who are responsible for the installation and commissioning of the inverter; and
- inverter owners who will have the ability to interact with the inverter.

## How to Use This Manual





Read the manual and other related documents before any work on the inverter is carried out. Documents must be stored carefully and be available at all times.

All rights to the content of this manual are owned by Sungrow Power Supply Co., Ltd. (hereinafter “SUNGROW”). No part of this document can be modified, distributed, reproduced or published in any form or by any means without prior written permission from SUNGROW.

Contents may be periodically updated or revised due to product development. The information in this manual is subject to change without notice. The latest manual can be acquired at [www.sungrowpower.com](http://www.sungrowpower.com).

## Symbols

Safety instructions will be highlighted with the following symbols.

Symbol	Explanation
 <b>DANGER</b>	Indicates a hazard with a high level of risk that, if not avoided, will result in death or serious injury.
 <b>WARNING</b>	Indicates a hazard with a medium level of risk that, if not avoided, could result in death or serious injury.
 <b>CAUTION</b>	Indicates a hazard with a low level of risk that, if not avoided, could result in minor or moderate injury.
<b>NOTICE</b>	Indicates a situation that, if not avoided, could result in equipment or property damage.
 <b>i</b>	Indicates additional information, emphasized contents or tips that may be helpful, e.g. to help you solve problems or save time.

# Contents

---

<b>About This Manual .....</b>	<b>1</b>
<b>1 Safety .....</b>	<b>1</b>
1.1 General Safety .....	1
1.2 Inverter .....	2
1.3 Skills of Qualified Personnel.....	3
<b>2 Product Introduction .....</b>	<b>4</b>
2.1 Intended Use .....	4
2.2 Inverter .....	5
2.2.1 Appearance .....	5
2.2.2 Dimensions and Weight .....	6
2.2.3 LED Indicator Panel .....	6
2.3 Function Description .....	7
2.4 AS4777:2015 Compliant.....	8
2.4.1 External Demand Response.....	8
2.4.2 Reactive Power Regulation.....	9
2.4.3 Power Quality Response.....	9
<b>3 Unpacking and Storage .....</b>	<b>10</b>
3.1 Unpacking and Inspection .....	10
3.2 Identifying the Inverter.....	11
3.3 Delivery Contents .....	12
3.4 Storage of Inverter.....	12
<b>4 Mechanical Mounting .....</b>	<b>13</b>
4.1 Safety during Mounting .....	13
4.2 Location Requirements.....	13
4.3 Installing the Inverter .....	16
<b>5 Electrical Connection .....</b>	<b>18</b>
5.1 Terminal Description .....	19

5.2	Connection Overview .....	19
5.3	Grounding the Inverter .....	20
5.4	Grid Connection.....	21
5.4.1	AC Side Requirements .....	21
5.4.2	Assembling the AC Connector.....	22
5.4.3	Installing the AC Connector .....	23
5.5	PV Connection .....	23
5.5.1	PV Inputs Configuration .....	24
5.5.2	Assembling the PV Connector.....	26
5.5.3	Installing the PV Connector.....	27
<b>6</b>	<b>Communication .....</b>	<b>29</b>
6.1	Communication Terminal .....	29
6.2	Distance Requirements .....	30
6.2.1	Scenario 1: No Barriers.....	30
6.2.2	Scenario 2: On Different Floors .....	31
6.2.3	Scenario 3: In Different Rooms on the Same Floor .....	32
6.3	SolarInfo Home APP.....	32
6.3.1	Acquisition and Installation.....	32
6.3.2	Visiting Inverter via “[Direct visit]” Mode .....	35
6.3.3	Visiting Inverter via “Remote [Login]” Mode .....	37
<b>7</b>	<b>Commissioning.....</b>	<b>39</b>
7.1	Inspection before Commissioning .....	39
7.2	Commissioning Procedure.....	39
<b>8</b>	<b>System Decommissioning .....</b>	<b>41</b>
8.1	Disconnecting the Inverter .....	41
8.2	Dismantling the Inverter.....	42
8.3	Disposing of the Inverter .....	42
<b>9</b>	<b>Troubleshooting and Maintenance .....</b>	<b>43</b>
9.1	Troubleshooting .....	43
9.1.1	For LED Indicator .....	43
9.1.2	For the Faults on the APP or Screen .....	44

9.2	Routine Maintenance .....	49
<b>10</b>	<b>FAQs for SolarInfo Wi-Fi .....</b>	<b>51</b>
10.1	Cannot Find Wi-Fi Signal of Inverter .....	51
10.2	Too Weak Wi-Fi Signal of Inverter.....	51
10.3	Cannot Find Wi-Fi Network of Router.....	53
10.4	Cannot Connect to Wi-Fi Network of Router .....	54
10.5	Transmission Signal Strength of Different Materials.....	56
10.6	Cannot Find Running Data on Server.....	56
<b>11</b>	<b>Appendix .....</b>	<b>57</b>
11.1	Technical Data.....	57
11.2	Exclusion of Liability .....	59
11.3	About Us .....	60





# 1 Safety

The inverter has been designed and tested strictly according to international safety regulations. Read all safety instructions carefully prior to any work and observe them at all times when working on or with the inverter.

Incorrect operation or work may cause:

- injury or death to the operator or a third party; or
- damage to the inverter and other properties belonging to the operator or a third party.

All detailed work-related safety warnings and notes will be specified at critical points in this manual.

## 1.1 General Safety

### PV Panels

Please follow the safety instructions related to the PV array.

#### **DANGER**

**Lethal voltage!**

**PV strings will produce electrical power when exposed to sunlight and can cause a lethal voltage and an electric shock.**

**Only qualified personnel can perform the wiring of the PV panels.**

### Utility Grid

Please follow the regulations related to the utility grid.

#### **NOTICE**

**All electrical connections must be in accordance with local and national standards.**

**Only with the permission of the utility grid, the inverter can be connected to the utility grid.**

## 1.2 Inverter

There is a warning label on the inverter body.



Disconnect the inverter from all the external power sources before service!



10 min

Do not touch live parts until 10 minutes after disconnection from the power sources.



There is a danger from a hot surface that may exceed 60°C.



Danger to life due to high voltages!  
Only qualified personnel can open and service the inverter.



Check the user manual before service!

### DANGER

#### **Danger to life from electric shocks due to live voltage**

- Do not open the enclosure at any time. Loss of any or all the rights may follow if otherwise.
- When the enclosure lid is removed, live components can be touched which can result in death or serious injury due to electric shock.

#### **Danger to life from electric shock due to damaged inverter**

- Only operate the inverter when it is technically faultless and in a safe state.
- Operating a damaged inverter can lead to hazardous situations that can result in death or serious injuries due to electric shock.

### WARNING

#### **Risk of inverter damage or personal injury**

**DO not pull out the PV connectors while the inverter is under AC loads!  
De-energize the inverter from dual power sources and verify that there is no voltage.**

 **WARNING**

**All the warning labels and nameplate on the inverter body:**

- must be clearly visible; and
- must not be removed, covered or pasted.

 **CAUTION**

**Risk of burns due to hot components!**

**DO not touch the hot parts (such as heat sink) during operation. Only the LED indicator panel and the optional DC switch can be touched.**

**NOTICE**

**Only qualified personnel can change the country setting.**

**Unauthorized alteration of the country setting may cause a breach of the type-certificate marking.**

**Inverter damage due to electrostatic discharge (ESD).**

**By touching the electronic components, you may damage the inverter. For inverter handling, be sure to:**

- **avoid any unnecessary touching; and**
- **wear a grounding wristband before touching any connections.**

## 1.3 Skills of Qualified Personnel

Qualified personnel must have the following skills:

- training in the installation and commissioning of the electrical system, as well as the dealing with hazards;
- knowledge of the manual and other related documents; and
- knowledge of the local regulations and directives.

## 2 Product Introduction

### 2.1 Intended Use

The inverters, which are single-phase string inverters without transformer, are the crucial units between the PV array and the utility grid in a PV power system.

The inverter is dedicated to converting the DC power generated by the PV array into the AC power, which conforms to the parameters of the local utility grid and is fed into the utility grid. An example about the intended use is shown in **Fig. 2-1**.

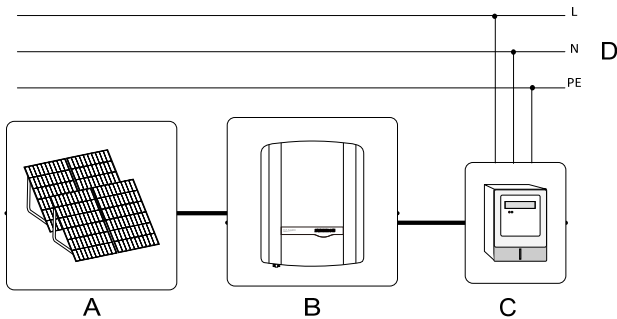

**Fig. 2-1** Application in a PV Power System

Item	Description	Remarks
A	PV strings	Monocrystalline silicon, polycrystalline silicon and thin-film without grounding
B	Inverter	SG2KTL-S, SG3KTL-S, SG3KTL-D or SG5KTL-D
C	Metering device	Meter cupboard with power distribution system
D	Utility grid	Line types: TT, TN

### **!** WARNING

**Any use other than the intended use is not permitted.**

**It is not permitted for the positive pole or the negative pole of the PV strings to be grounded.**

**NOTICE**

**For the TT utility grid, the N line voltage to ground must be less than 30 V.**

**Do not connect local loads (such as home appliances, lights, motor loads, etc.) between the inverter and the AC circuit breaker.**

## 2.2 Inverter

### 2.2.1 Appearance

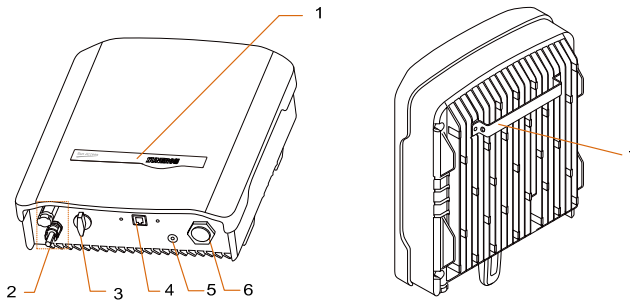
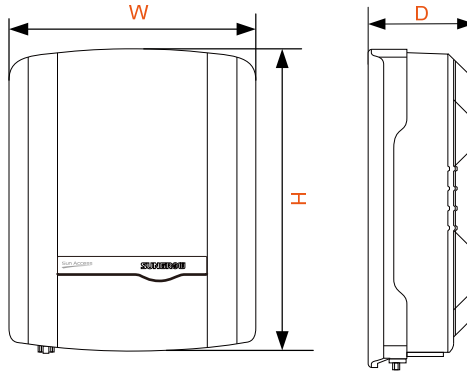

**Fig. 2-2** Inverter Appearance

\* The image shown here is for reference only. The actual product you receive may differ.

Item	Name	Description
1	LED indicator panel	Human-computer interaction interface.
2	DC terminals	To connect the PV array. A pair or two pairs.
3	DC switch (optional)	To disconnect the DC current safely.
4	RS485 terminal	To connect the Wi-Fi module, eShow module, or ZE100 module.
5	Second PE terminal	For reliable grounding.
6	AC terminal	To feed power into the utility grid.
7	Mounting rack	To hang the inverter to the wall-mounting bracket.

## 2.2.2 Dimensions and Weight



**Fig. 2-3** Dimensions of the Inverter

**Tab. 2-1** Dimensions and Weight

Type	W(mm)	H(mm)	D(mm)	Net weight(kg)
SG2KTL-S/SG3KTL-S	300	370	125	9
SG3KTL-D/SG5KTL-D	360	390	133	11

## 2.2.3 LED Indicator Panel

User can observe the color and blinking frequency of the indicator to get the current state of the inverter.



**Fig. 2-4** LED Indicator Panel

For indicator state descriptions, see **Tab. 7-1**.



The LED indicator will be red and green at the same time when the inverter is in upgrade status. If in other status, please contact the service provider for troubleshooting.

## 2.3 Function Description

Inverter functions can be grouped as follows:

- Conversion function  
Inverter converts the DC power into the AC power, which conforms to the grid requirement of its installation country.
- Data storage  
Inverter archives essential data including running information and fault records.
- Parameter configuration  
Inverter provides various parameter configurations for optimal operation. You can set the country by APP, if you need a more professional setting, please contact SUNGROW.
- Communication interface  
You can choose the RS485 terminal for connecting a communication or monitoring device to the PV system, such as eShow, eShow+, ZE100 and so on.
- Earth fault alarm  
If an earth fault occurs, the fault code will be displayed on the LCD screen of eShow/eShow+/ZE100. The buzzer inside the eShow/eShow+/ZE100 will beep to signal an external alarm.
- Protection functions include:
  - short circuit protection;
  - grounding insulation resistance surveillance;
  - inverter output voltage surveillance;
  - inverter output frequency surveillance;
  - residual current protection;
  - DC injection of AC output current surveillance;
  - anti-islanding protection;
  - ambient temperature surveillance;
  - DC overvoltage protection;
  - overcurrent protection; and
  - over-temperature protection.

## 2.4 AS4777:2015 Compliant

The inverter supports the demand response modes (DRMs), the reactive power regulation, and the power quality response, as specified in the standard AS 4777:2015.

- External Demand Response
- Reactive Power Regulation
- Power Quality Response

For details about the connection and settings, see the Quick User Manual delivered with the eShow module or ZE100 module.

### 2.4.1 External Demand Response

The inverter provides a RJ45 port for connecting to the communication module eShow/eShow+/ZE100 that with a DRM port for connecting to a demand response enabling device (DRED). The DRED asserts demand response modes (DRMs). The inverter detects and initiates a response to the supported demand response commands within 2 s.

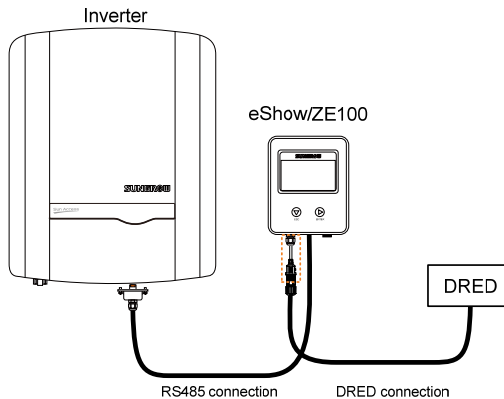

**Tab. 2-2** Demand Response Modes (DRMs)

Mode	Explanation
DRM0	The inverter is in the state of standby.
DRM5	The export power to the grid is 0%.
DRM6	The export power to the grid is no more than 50% of the rated power.
DRM7	The export power to the grid is no more than 75% of the rated power.
DRM8	The export power to the grid is 100%, but subject to the constraints from other active DRMs.



## 2.4.2 Reactive Power Regulation

The inverter is capable of operating in reactive power regulation modes for the purpose of providing support to the grid. These various operating modes can be enabled or disabled via the LCD menu.

- **PF:** Fixed power factor mode.
- **Qt:** Fixed reactive power mode.
- **Q(p):** The PF of the inverter output varies in response to the output power of the inverter.
- **Q(u):** The reactive power output of the inverter varies in response to the grid voltage.

## 2.4.3 Power Quality Response

The inverter supports two power quality response modes, which can be set via the LCD menu.

- **Power derating for voltage variations:**

Define the response curve with four reference voltages. The power output or input will vary in response to the voltage curve.

- **Power derating for frequency variations:**

Define the response curve with a start frequency and an end frequency. The inverter will reduce the power output in response to an increase in grid frequency.

## 3 Unpacking and Storage

### 3.1 Unpacking and Inspection

The inverter is thoroughly tested and strictly inspected before delivery. Damage may still occur during shipping. Conduct a thorough inspection after receiving the device.

1. Check the packaging for any visible damage.
2. Check the inner contents for damage after unpacking.
3. Check the delivery contents for completeness according to the packaging list.

Contact SUNGROW or the distributor in case of any damaged or missing components.

It is the best choice to store the inverter in the original packaging. So, do not dispose of it.

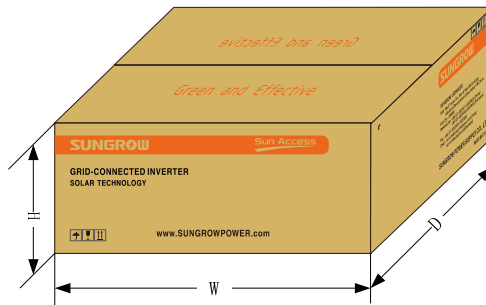

Fig. 3-1 Single Inverter Packaging

Type	W (mm)	H (mm)	D (mm)
SG2KTL-S/SG3KTL-S	500	210	385
SG3KTL-D/SG5KTL-D	530	215	445

### 3.2 Identifying the Inverter

The nameplate clearly identifies the product. It is attached to the side of the inverter.

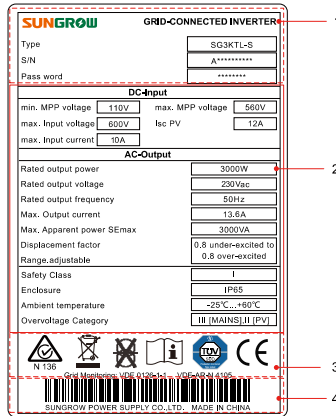



Fig. 3-2 Nameplate of Inverter

\* The image shown here is for reference only. The actual product you receive may differ.

Item	Description	Item	Description
1	SUNGROW logo and product type	3	Marks of certification institutions
2	Technical data	4	Barcode, company name and origin

Tab. 3-1 Description of Icons on the Nameplate

Icon	Description
	C-tick mark of conformity.
	Do not dispose of the inverter together with household waste.
	The inverter does not have a transformer.
	Refer to the corresponding instructions.
	CE mark of conformity.

Icon	Description
	TUV mark of conformity.

### 3.3 Delivery Contents

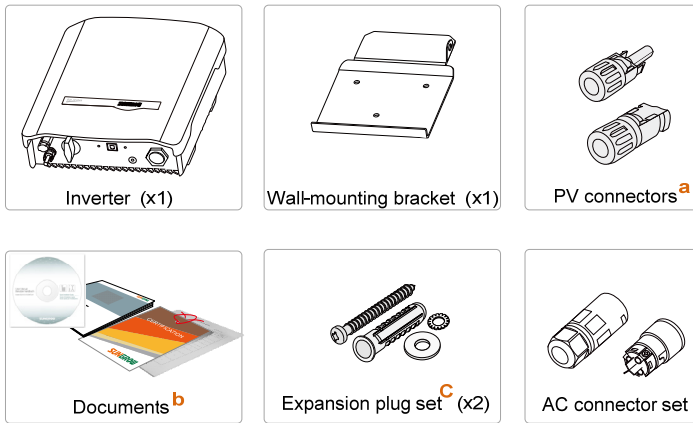

**Fig. 3-3** Delivery Contents

- One pair for the –S series and two pairs for the –D series.
- The documents include the Quick User Manual, 1 CD, quality certificates, packaging list and product test reports.
- It is delivered only for the countries except Australia.

### 3.4 Storage of Inverter

If you do not install the inverter immediately, choose an appropriate location to store it.

- Store the inverter in the original packaging with the desiccant inside.
- The storage temperature should be always between  $-30^{\circ}\text{C}$  and  $+85^{\circ}\text{C}$ , and the storage relative humidity should be always between 0 and 100%.
- If there is more than one inverter to be stored, the maximum layer is 9.
- The packaging should be upright.

## 4 Mechanical Mounting

### 4.1 Safety during Mounting

#### DANGER

**Make sure there is no electrical connection before installation.**

**In order to avoid electric shock or other injury, be sure there is no electricity or plumbing installations before drilling holes.**

#### CAUTION

**Risk of injury due to improper handling**

- **The weight can cause injuries, serious wounds, or bruise.**
- **Always follow the instructions when moving and positioning the inverter.**

**System performance loss due to bad ventilation!**

- **The inverter requires good ventilation during operation. Keep it upright and nothing covering the heat sink.**

#### NOTICE

**Wear gloves to avoid scratches when mounting the inverter.**

### 4.2 Location Requirements

The inverter with IP65 can be installed indoors or outdoors.

Selecting an optimal location for the inverter is critical for its operating safety as well as the expected efficiency and service life. Considerations for the location include:

1. The concrete wall should be suitable for the weight and dimensions of the inverter.
2. Install the inverter where it is convenient for installation, cable connection and service.

3. Do not install the inverter in the living area or bedrooms. The noise during its operation may affect daily life.
4. The location should be not accessible to children.
5. The max. output power will reduce when the ambient temperature exceeds 45°C. The following figure shows the ambient temperature and relative humidity limits.

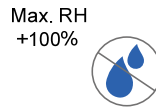
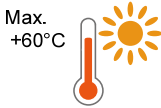

6. The location should be not flammable materials (except the wooden wall), away from flammable materials or gas, and not enclosed.

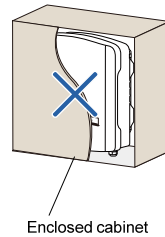
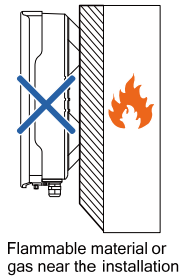
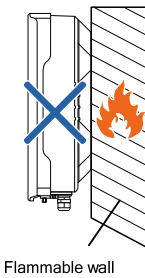

7. The shaded side of the building would be better to prevent the inverter from exposure to the sun, rain, and snow.

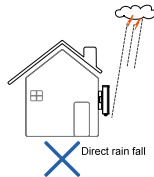
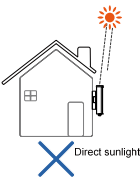
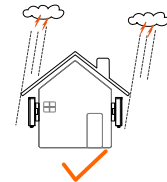
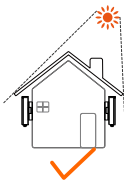

8. Place at eye level for easy viewing:

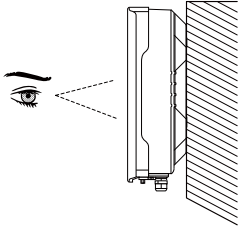

9. Install vertically for good heat dissipation.

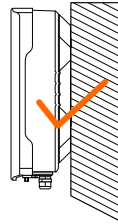

10. Never install the inverter horizontally, or with a forward tilt or with a backward tilt or even with upside down. The horizontal installation could result in damage to the inverter.

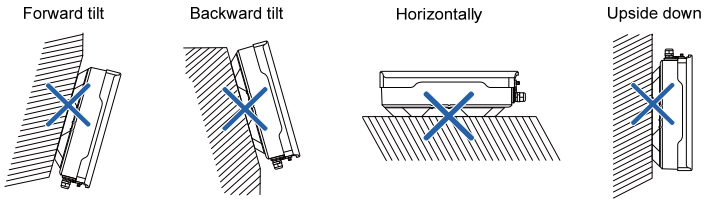

11. Clearance requirement and multiple installation:

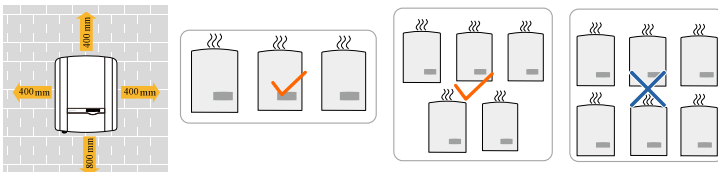

For multi-row installation, the distance between two adjacent rows should be at least 400 mm.

Refer to **"6.2 Distance Requirements"** for details if a Wi-Fi module or ZE100 is equipped.

### 4.3 Installing the Inverter

Inverter is installed on the wall by means of wall-mounting bracket and the expansion plug sets.

The expansion plug set shown below is recommended for the installation.

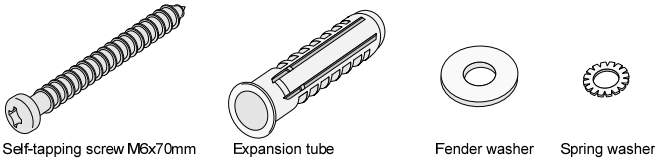

1. Place the wall-mounting bracket to the wall and adjust it until it is in a horizontal position. Mark the positions.

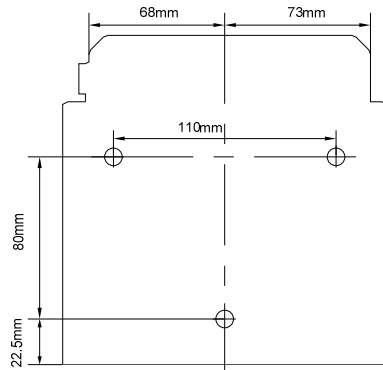

2. Drill holes and install the wall-mounting bracket. The depth of the holes should be about 70 mm.

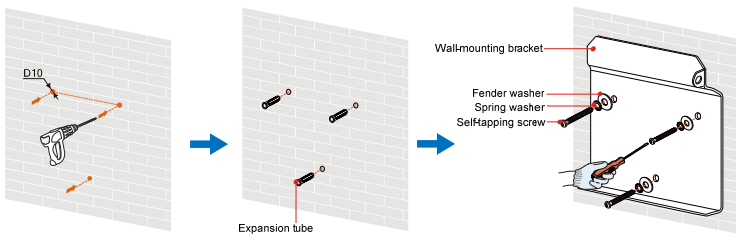



3. Mount the inverter to the bracket, and secure it with an M4 screw (torque: 1.5 N·m).

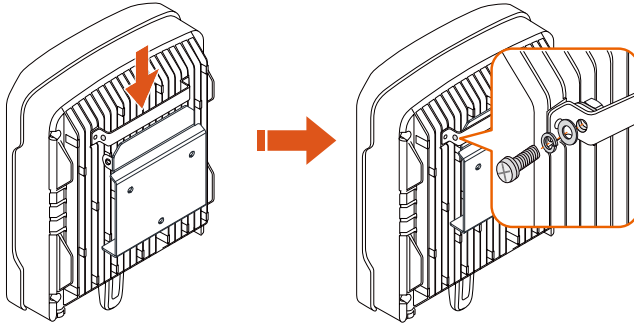

4. **(Optional)** Install the communication module to the inverter. The following figure takes the eShow module as an example.

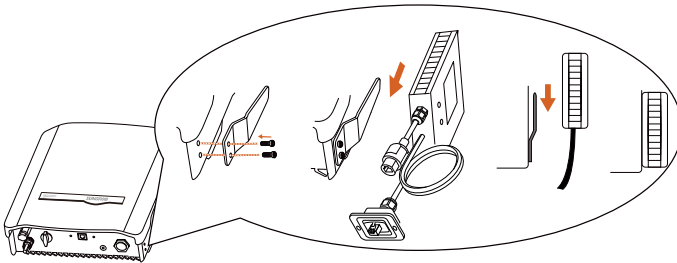

Refer to the manual delivered with the module for details.



- eShow module: eShow User Manual
- ZE100: ZE100 Quick Installation Guide

## 5 Electrical Connection

Prior to any electrical connections, keep in mind that the inverter has dual power supplies. It is mandatory for the technical personnel to wear personal protective equipments (PPE) during the electrical work: helmet, footwear and gloves.

### DANGER

**Danger to life due to a high voltage inside the inverter**

- **Make sure that the cables are not live before electrical connection.**
- **Do not turn on the AC circuit breaker until all the electrical connections are completed.**

### WARNING

**Improper operation during the wiring process can cause fatal injury to the operators or unrecoverable damage to the inverter.**

**Only qualified personnel can perform the wiring work.**

**All cables must be firmly attached, undamaged, properly insulated and adequately dimensioned.**

### NOTICE

**Comply with the safety instructions related to the PV array and the regulations related to the utility grid.**

**All electrical connections must be in accordance with local and national standards.**

**Only with the permission of the utility grid, the inverter can be connected to the utility grid.**

## 5.1 Terminal Description

All electrical terminals are located at the bottom of the inverter.

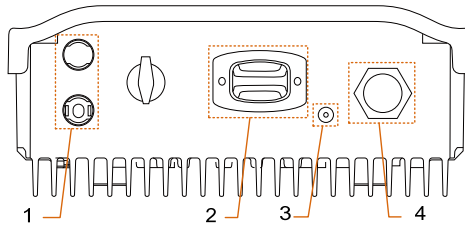

**Fig. 5-1** Terminal Description

\* The image shown here is for reference only. The actual product you receive may differ.

**Tab. 5-1** Terminal Descriptions

Item	Terminal	Description
1	DC	MC4 terminals for PV input.
2	RS485 terminal	For Wi-Fi module, eShow module, or ZE100 module.
3	Second PE terminal	For reliable grounding.
4	AC	The AC terminal to the utility grid.

## 5.2 Connection Overview

Electrical connections of the inverter include grounding, DC connection and AC connection. Refer to **Chapter 6** for the communication connection.

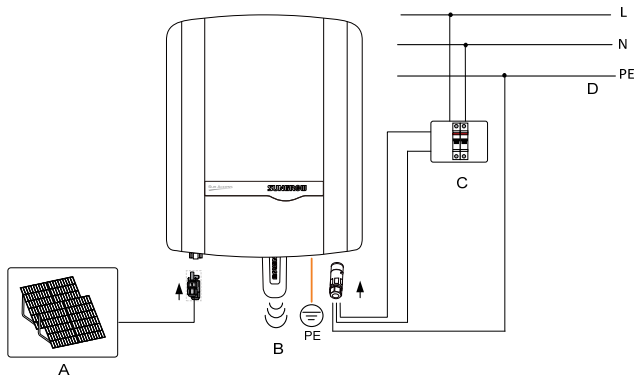

**Fig. 5-2** Electrical Connection Diagram

Item	Name	Remarks
A	PV array	-S series: one input area with one pair of terminals. -D series: two input areas with two pairs of terminals.
B	Communication module	Take the SolarInfo Wi-Fi module as an example.
C	AC circuit breaker	Used as a protective device during electrical connection. User equips this device according to the maximum output voltage and current. The PE wire of the AC terminal must be directly connected to the grounding bar. Do not connect it to protection devices such as circuit breaker.
D	Utility grid	Nominal line-to-neutral voltage of the utility grid is 220 Vac/230 Vac.

#### NOTICE

**If there are several inverters connected to the grid in parallel, each phase of the transformer can connect 10 inverters at most. Please contact SUNGROW for a technical evaluation if more than 10 inverters are connected.**

### 5.3 Grounding the Inverter

All non-current carrying exposed metal parts of the equipment and other enclosures in the PV power system should be grounded, e.g. PV array frame and inverter enclosure.

A second Protective Earth (PE) terminal is equipped at the bottom of the inverter. Be sure to connect this PE terminal for reliable grounding.

#### WARNING

**In no case shall the second PE connection substitute for the PE connection in the AC terminal block. Be sure to connect both PE terminals for reliable grounding. The loss of any or all rights may follow if otherwise.**

**Because of the transform-less design of the inverter, neither the DC positive pole nor the DC negative pole are permitted to be grounded. A permanent destroy to the inverter may follows if otherwise.**

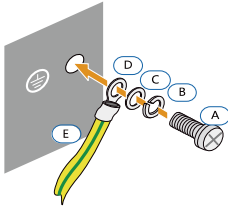

Item	Description
A	Screw (M4×12 mm)
B	Spring washer
C	Washer
D	Cable socket
E	Yellow-green cable

**Fig. 5-3** Second PE Connection

\* The cross-section of the PE cable should be at least 10 mm<sup>2</sup> if copper or 16 mm<sup>2</sup> if aluminum. The connection parts are not included in the delivery scope.

## 5.4 Grid Connection

The inverter is connected to the grid via 3 wires (L, N and PE).

Inverter is equipped with the water-proof direct plug-in connector which matches the AC terminal at the bottom of the inverter.

### 5.4.1 AC Side Requirements

#### AC Circuit Breaker

An independent two-pole AC circuit breaker for the inverter must be installed at the output side for safe disconnection. The recommended specifications are as follows:

Inverter Type	Specification
SG2KTL-S/SG3KTL-S/SG3KTL-D	25A
SG5KTL-D	32A

#### NOTICE

- It is not allowed for several inverters to use the same AC circuit breaker.
- It is not allowed to connect loads between the inverter and the AC circuit breaker.

#### Residual Current Device

With an integrated universal current-sensitive residual current monitoring unit inside, the inverter will disconnect immediately from the mains power as soon as a fault current with a value exceeding the limit has been detected.

However if an external residual current device (RCD) is mandatory, the switch must be triggered at a failure current of 300 mA or higher.

## AC Cable Requirements

The recommended specifications are shown in the following table

Type	Cross-section (mm <sup>2</sup> )		Cable diameter (mm)	
	Range	Recommended	Range	Recommended
SG2KTL-S/SG3KTL-S/ SG3KTL-D	4...6	4	10...14	14
SG5KTL-D	4...6	6	10...14	14

### 5.4.2 Assembling the AC Connector

1. Lead the AC cable through the cable gland and the housing.
2. Remove the cable jacket by 40 mm, and strip the wire insulation by 8-15 mm.

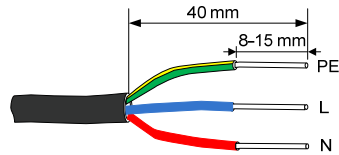
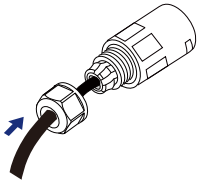

3. Fully insert the conductors to the corresponding terminal and tighten the screws with the torque 1.2 N·m. Pull cables outward to check whether they are firmly installed.

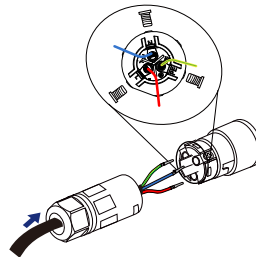

#### NOTICE

**Observe the terminal layout of AC connector.**

**Do not connect the phase lines to "PE" terminal, otherwise the inverter will not function properly.**

4. Assemble the housing, the terminal block and cable gland. Make sure that the rib of the terminal block and the groove on the housing engage perfectly until a “Click” is heard or felt.

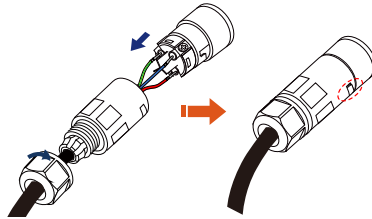

### 5.4.3 Installing the AC Connector

1. Disconnect the AC circuit breaker and secure it against reconnection.
2. Align the AC connector and the AC terminal and mate them together by hand until a “Click” is heard or felt.

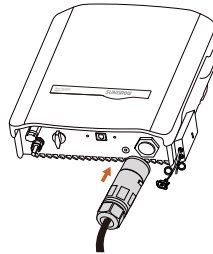

3. Connect the other ends. Connect “PE” conductor to the grounding electrode. Connect “L” and “N” conductors to the AC circuit breaker.
4. Connect the AC circuit breaker to the utility grid. Pull all the lines outward to check whether they are firmly installed.

## 5.5 PV Connection

### WARNING

**Before connecting the PV array to the inverter, make sure that the impedances between the positive terminal of the PV string and Earth, and the impedances between the negative terminal of the PV string and Earth are larger than 200Kohm.**

**NOTICE**

**There is a risk of inverter damage! The following requirements should be met; otherwise they will lead to loss of any and all warranty rights.**

- **Make sure that the maximum short circuit current of each DC input is less than inverter allowable limit.**
- **Make sure that the maximum open voltage of each string is less than 600V. Voltage over 600 V can damage the inverter.**

**5.5.1 PV Inputs Configuration**

**-S Series**

There is one input area with one MPP tracker. Only one input can be connected, as shown in the following figure.

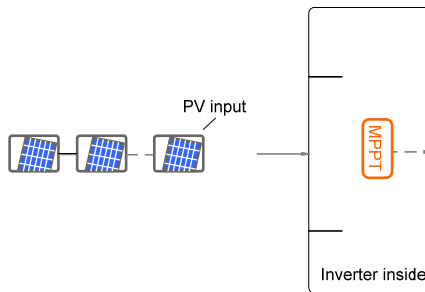

Type	Total DC Input Power Limit	Open-circuit Voltage Limit	Short-circuit Current Limit
SG2KTL-S	3000 W	600 V	12 A
SG3KTL-S	4000 W	600 V	12 A

**-D Series**

There are two PV input areas, each with its MPP tracker. The two PV inputs can be configured in independent mode or parallel mode.

- Independent Mode

The two PV inputs work independently, each with its own MPPT. The two PV inputs can be different from each other in PV module types, numbers of PV panels in PV string, tilt angles and orientation angle of PV modules.



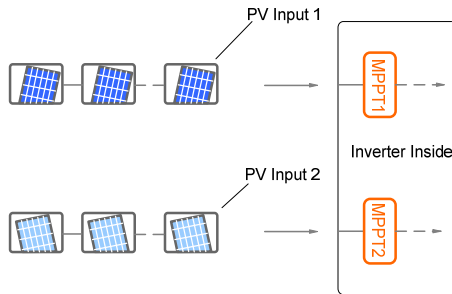

To make sure the maximum DC power, PV strings connected to individual input area should have a homogenous structure, i.e. the same type, identical tilt and identical orientation.

Prior to connecting the inverter to PV inputs, the specifications in the following table should be met:

Type	Total DC Input Power Limit	Open-circuit Voltage Limit (DC1/DC2)	Short-circuit Current Limit (DC1/DC2)
SG3KTL-D	4000 W	600 V/600 V	12 A/12 A
SG5KTL-D	6500 W	600 V/600 V	12 A/12 A



Only the current is limited for a single input and the power is not limited.

• Parallel Mode

All PV strings should have the same type, the same number of PV panels, identical tilt and identical orientation.

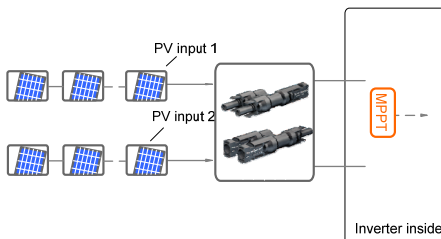

Prior to connecting the inverter to PV inputs, the specifications in the following table should be met:

Type	Total DC Input Power Limit	Open-circuit Voltage Limit	Short-circuit Current Limit
SG3KTL-D	4000 W	600 V	24 A
SG5KTL-D	6500 W	600 V	24 A



To avoid the input power unbalance of the two inputs or input load-restriction, ensure the two PV input cables are of the same model.

### 5.5.2 Assembling the PV Connector

All DC cables are equipped with the water-proof direct plug-in connectors which match the DC terminals at the bottom of the inverter.

#### NOTICE

**The DC cables must be multi-stranded wires.**

**To ensure the protection degree IP65, only use the connectors delivered or connectors with the same degree of protection.**

The requirements of DC cables are as follows.

Cross-section	Cable Diameter	Max. Withstand Voltage	Max. Withstand Current
2.5...6 mm <sup>2</sup>	5...8 mm	600 V	Same with short-circuit current

Procedure:

- Strip the insulation from the cables by 7 mm.
- Assemble the cable ends by crimping pliers.

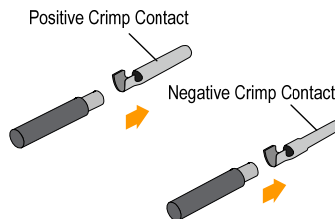
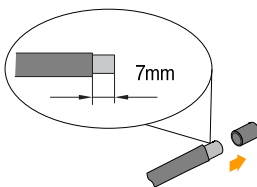

3. Lead the cable through cable gland, and insert into the insulator until it snaps into place. Then tighten the cable gland (torque 2.5 N·m to 3 N·m).

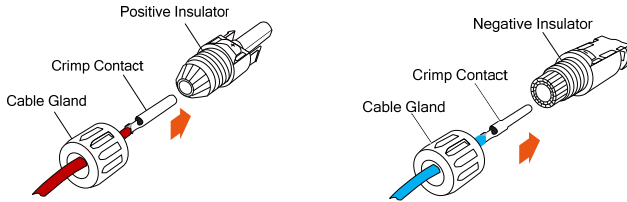

4. Make sure that the cable polarities of the PV string are correct.

#### NOTICE

**The inverter will not function properly if the DC polarities are reversed.**

### 5.5.3 Installing the PV Connector

#### NOTICE

**There is a risk of inverter damage! The following requirements should be met, otherwise they will lead to loss of any and all warranty rights.**

- **Make sure that the maximum short circuit current of each DC input is less than inverter allowable limit.**
- **Make sure that the maximum open voltage of each string is less than 600V. Voltage over 600 V can damage the inverter.**

Connect the inverter to PV array according to the following procedure.

1. **(Optional)** If you purchase the DC switch, rotate it to "OFF".

Optional

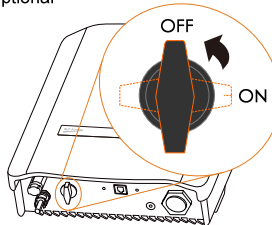

2. Check the connection cable of the PV string for the correct polarity and that the open-circuit voltage does not exceed the inverter input limit of 600 V, even under the lowest operating temperature. Refer to the module specification supplied by the module manufacturer for detailed information.

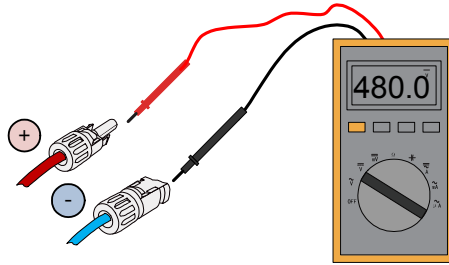

**NOTICE**

**The inverter will not function properly if the DC polarities are reversed. Check the positive and negative polarities of the PV cells before installation.**

- 3. For -D series, configure PV configuration mode according to actual PV conditions. Please refer to "-D Series".
- 4. Plug the positive and the negative DC connectors into corresponding terminal until there is an audible click.

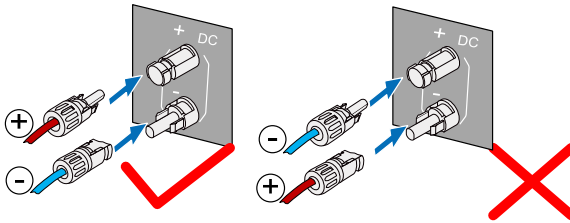

\* The image shown here is for reference only. The actual product you receive may differ.

- 5. Seal the unused DC terminals with the terminal caps.

# 6 Communication

## 6.1 Communication Terminal

The RS485 communication terminal is located at the bottom of the inverter. User can connect a communication module or cable to the terminal.

Module/Cable	Function
SolarInfo Wi-Fi module	Communication between the inverter and the smart phone can be established via SolarInfo Wi-Fi. Use SolarInfo Home APP to set the country and protection parameters according to the permissible range of the utility grid. Refer to the User Manual of Wi-Fi for details.
eShow (LCD display)	Perform the LCD operation to set the country and protection parameters according to the permissible range of the utility grid. Refer to <i>eShow User Manual</i> for details.
ZE100	ZE100 mainly provides the zero export function, LCD display and so on. Refer to the <i>ZE100 User Manual</i> or <i>ZE100 Quick Installation Guide</i> for details.

If a RS485 cable is connected to the terminal, use a Ethernet crimpers to crimp wires and connect the wires to the RJ45 plug according to TIA/EIA 568B standard.

Pin 3 (white-green wire as RS485 B) and pin 6 (green wire as RS485 A) are used for communication. Please do not use pins 1, 2, 4 and 5. Refer to the figure below.

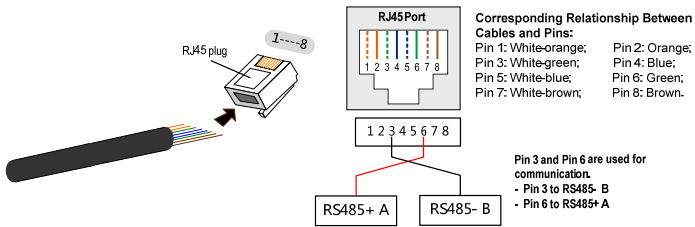

This chapter mainly describes the communication between the inverter and the smartphone/router. Refer to "**10 FAQ for SolarInfo Wi-Fi Installation and Configuration**" for any problems.

## 6.2 Distance Requirements

### 6.2.1 Scenario 1: No Barriers

If there are no barriers between the inverter and the smartphone/router, the maximum linear distance between them can be 100 m.

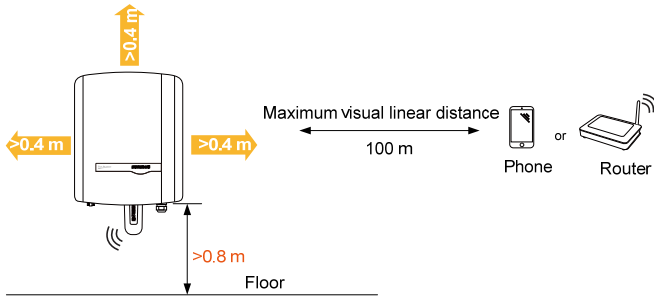

If the smartphone is connected to the router, the effective distance between them depends on the technical parameters of the router and the external environment.

**Tab. 6-1** Influence to Signal Strength of Different Materials

Material	Wireless signal strength	Possible Environment
Wood		Compartment
Plaster/Asbestos		Wall
Glass		Window
Water		Aquarium, pool, fish tank
Brick wall		-
Marble		Floor
Reinforced concrete		Floor panels, wall
Metal		Iron sheet

Material	Wireless signal strength	Possible Environment
Cordless smartphones, microwave ovens		-

### 6.2.2 Scenario 2: On Different Floors

The inverter and the smartphone/router can be located in different floors of a building, yet the floors must be adjacent.

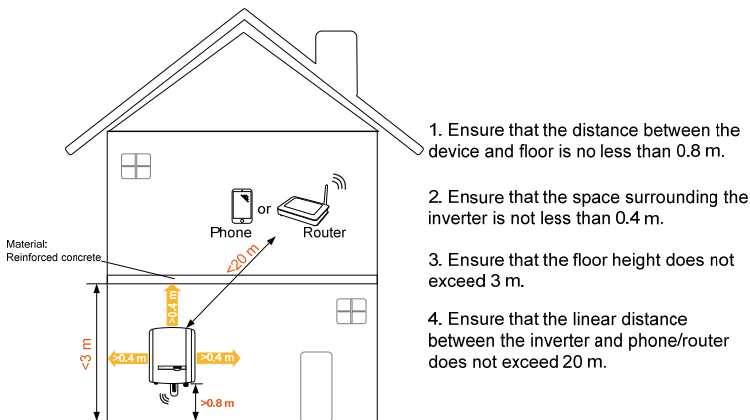

1. Ensure that the distance between the device and floor is no less than 0.8 m.
2. Ensure that the space surrounding the inverter is not less than 0.4 m.
3. Ensure that the floor height does not exceed 3 m.
4. Ensure that the linear distance between the inverter and phone/router does not exceed 20 m.

\* The image shown here is for reference only. The inverter can be installed indoors or outdoors.

### 6.2.3 Scenario 3: In Different Rooms on the Same Floor

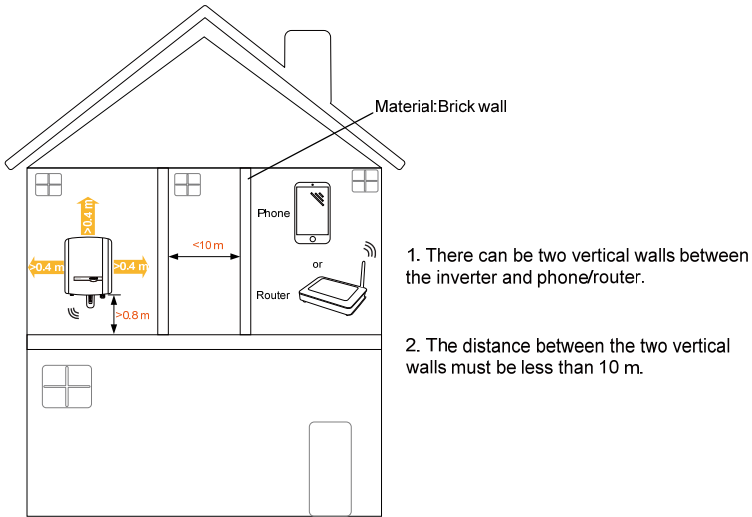

- The Wi-Fi module cannot be blocked by metal. Keep the inverter at the same height as the external antenna of the router.
- In order to avoid wireless electromagnetic interference, please keep the inverter away from equipment such as cordless smartphones, microwave ovens and so on.
- Do not install the inverter in confined environment, such as the basement.

## 6.3 SolarInfo Home APP

### 6.3.1 Acquisition and Installation

Download the SolarInfo Home APP and install it into your smartphone. You can select the APP version for iOS or Android.

#### For iPhone (iOS)

Scenario 1



The address for downloading SolarInfo Home APP is <https://itunes.apple.com/us/app/solarinfo-home/id906260039?l=zh&ls=1&mt=8>. Or scan the QR code on the right side.



For iOS

**Scenario 2**

Search for SolarInfo Home in your APP Store, from which you can download it and complete the installation.

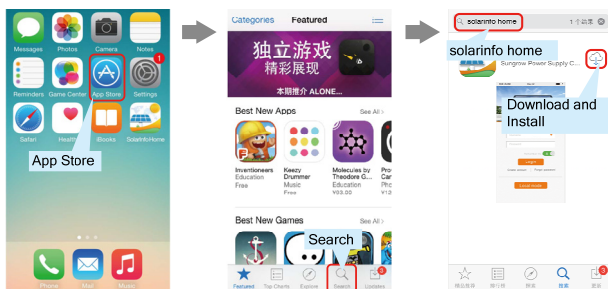

**For Android**

**Scenario 1**

The address for downloading SolarInfo Home APP is <https://play.google.com/store/apps/details?id=com.sungrow.home>. or [Http://www.solarinfobank.com/app/SolarInfoHome\\_v1.0.apk](http://www.solarinfobank.com/app/SolarInfoHome_v1.0.apk). Or scan the following QR codes.



For Android

Scenario 2

Search for SolarInfo Home in your Play Store, from which you can download it and complete the installation.

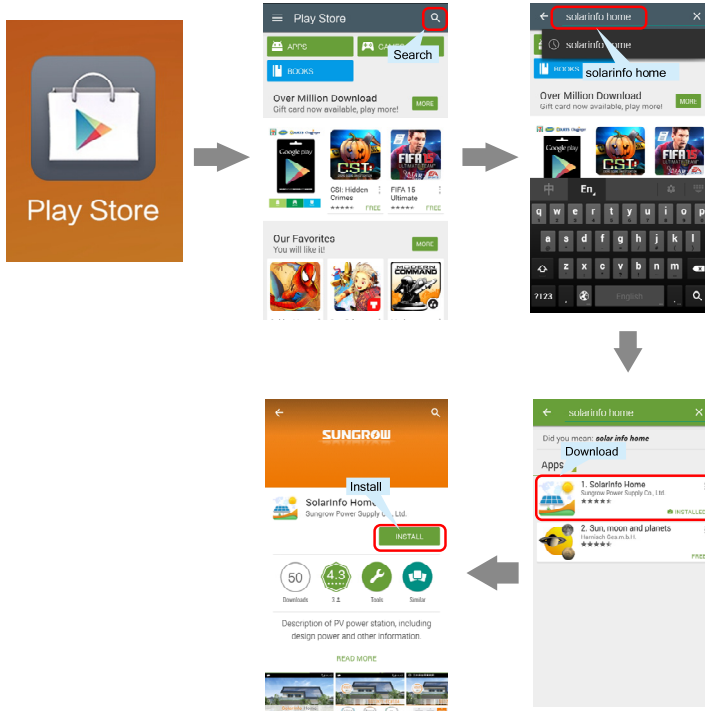

SolarInfo Home APP supports two kinds of operation: “[Direct visit]” and “Remote [Login]”.



- In “[Direct visit]” mode, you can connect your smartphone to the inverter directly via Wi-Fi to check the inverter information.
- In “Remote [Login]” mode, you need configure the inverter to connect it to your router and complete registration. Then you can log into SolarInfo Home via the Internet to check the device running information anywhere.

### 6.3.2 Visiting Inverter via "[Direct visit]" Mode



To perform the operations in this section, be sure that the distance between the smartphone and the inverter is within the valid range.

#### Checking Information

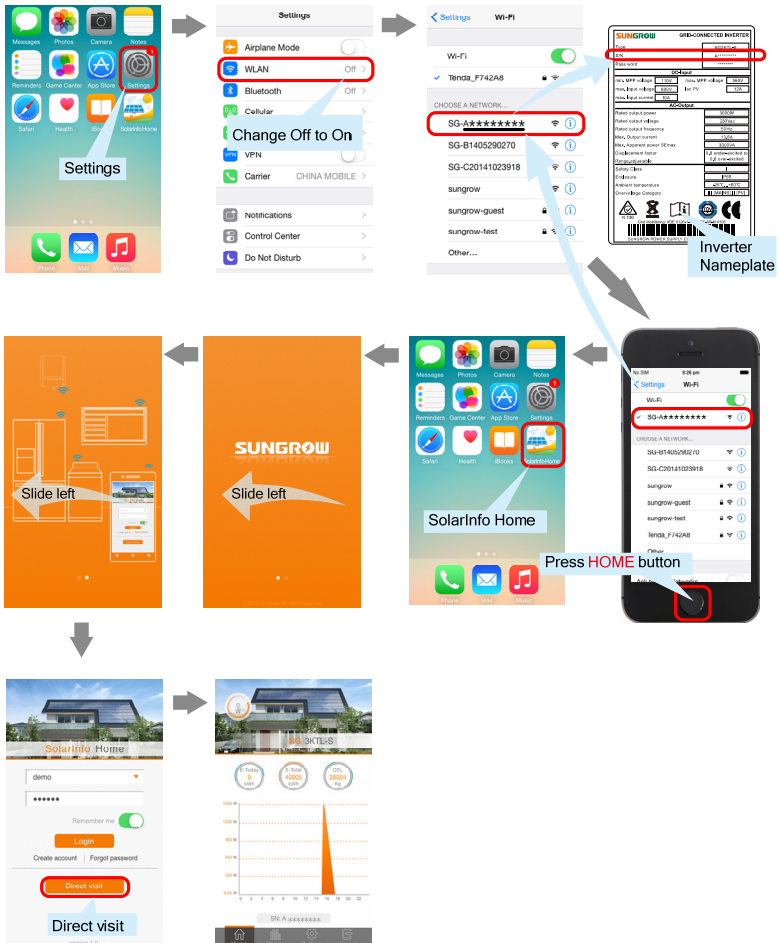

### Country Selection and Router Connection

#### NOTICE

To visit the inverter via "Remote [Login]" mode and check information anywhere, firstly connect the inverter to home router.

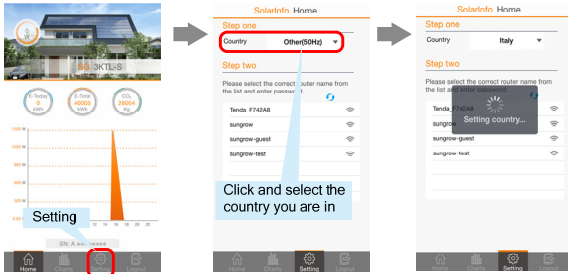

**NOTE**  
Please do not name your WiFi network started with "SG". Otherwise you cannot find it.

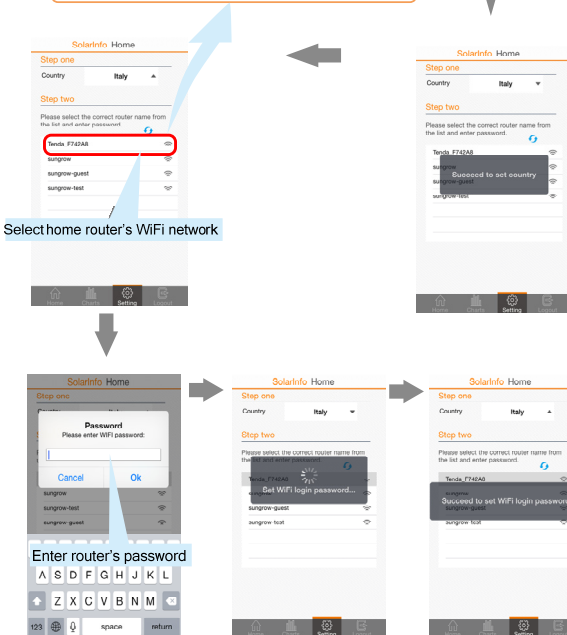

### 6.3.3 Visiting Inverter via “Remote [Login]” Mode

Complete the registration and you can then log into SolarInfo Home via the Internet to view the information wherever you happen to carry the device.

#### Registration



### NOTICE

- The e-mail address will be used to receive relevant mails, so it must be valid.
- The username will be needed to find the forgotten password. If you forget the username, re-register.

### Login

To perform the operations in this section, be sure that your phone can access the Internet.

### NOTICE

Be sure that you have connected the inverter to home router before login.

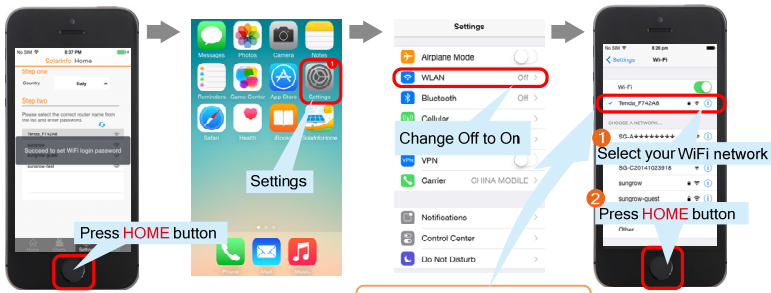

NOTE  
The router must be connected to the Internet.

NOTE  
The account and password are what you have registered.

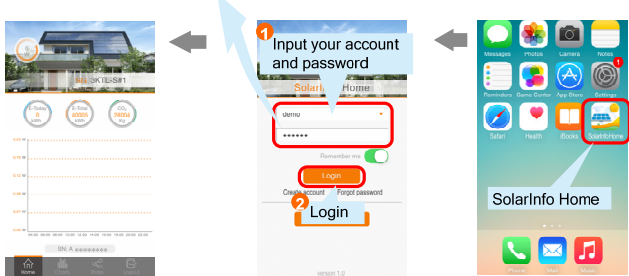

# 7 Commissioning

After setting the country parameter, set other parameters according to the specific requirements of the local grid. Check thoroughly if the parameters meet the requirements before commissioning.

## 7.1 Inspection before Commissioning

Check the following items before starting up the inverter:

1. The inverter is firmly secured and the site is accessible for operation, maintenance and service.
2. The room for ventilation is provided and nothing is left on top of the inverter.
3. Inverter and accessories are correctly connected. Cables are routed in a safe place and protected against mechanical damage.
4. The specification of the AC circuit breaker is reasonable.
5. The terminals that are unused underneath the inverter are sealed.
6. Warning signs and labels are suitably affixed and durable.

## 7.2 Commissioning Procedure

Make sure all the above mentioned items meet the requirements.

1. Turn on the external AC circuit breaker.
2. **(Optional)** Rotate the DC switch to **"ON"**.
3. If there is sufficient sunlight, the inverter will enter the running state and start to feed AC power to the grid.
4. Observe the status of the LED indicator.

**Tab. 7-1** Indicator Stage Description

State		Description
Green& Red	Flash once in turn every 1 s.	Non-running or Non-fault. (e.g., standby)
Green <sup>(1)</sup>	Flash once every 0.2-2 s. The higher the inverter power, the faster the flash.	Inverter is running normally.
	Flash once after every 2 s.	Earth fault <sup>(3)</sup>
Red <sup>(2)</sup>	Flash twice after every 2 s.	Grid side fault
	Flash 3 times after every 2 s.	ISO fault
	Flash 4 times after every 2 s.	Relay fault
	Flash 5 times after every 2 s.	Leakage current sensor self-detection fault
	Flash continuously.	Other faults

(1) The flashing period of the green light is inversely proportional to the power production of the inverter.

(2) The flashing duration of the red light is 0.3 s.

(3) The earth fault buzzer will beep when the eShow module is connected.



The LED indicator will be red and green at the same time when the inverter is in its upgrading process. If in other status, please contact SUNGROW Service Dept. for troubleshooting.



## 8 System Decommissioning

### 8.1 Disconnecting the Inverter

For maintenance or other service work, the inverter must be switched off.

Proceed as follows to disconnect the inverter from the AC and DC power sources. Lethal voltages or damage to the inverter will follow if otherwise.

1. Disconnect the AC circuit breaker and secure it against reconnection.
2. Rotate DC switch to "OFF". Disconnect the external DC circuit breaker.

#### NOTICE

**Please strictly follow the sequence of the above procedures. Inverter will not work normally if otherwise.**

3. Wait about 10 minutes until the capacitors inside the inverter completely discharge.
4. Measure to confirm that the AC output at the AC circuit breaker is voltage free.
5. Remove the AC connector. Lay the tool in the location of snap and press the tool down. Then snap can be pushed from the AC terminal.
6. Release the locking part of DC connectors by pressing on the ribbing of the locking hooks with nipper pliers and pull it outwards.

Press the ribbing

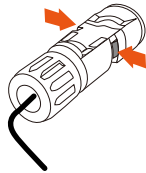

Pull outwards



Disconnect DC connectors

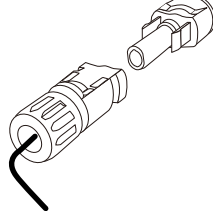

For further disconnection and conductor reconnection instruction, please visit the webpage of device manufacturer.

## 8.2 Dismantling the Inverter

### CAUTION

**Risk of burn injuries and electric shock!**

**Do not touch any inner live parts until at least 10 minutes after disconnecting the inverter from the utility grid and the PV input.**

1. Refer to **Chapter 5** for the inverter disconnection of all cables in reverse steps.
2. Dismantle the inverter referring to **Chapter 4** in reverse steps.
3. If necessary, remove the wall-mounting bracket from the wall.
4. If the inverter will be reinstalled in the future, please refer to “**3 Unpacking and Storage**” for a proper conservation.

## 8.3 Disposing of the Inverter

Users should take the responsibility for the disposal of the inverter.

### NOTICE

**Some parts and devices of the inverter, such as, LED indicators, batteries, capacitors, may cause environment pollution.**

**Disposal of the inverter must comply with the related local regulations to avoid the potential pollution.**

# 9 Troubleshooting and Maintenance

## 9.1 Troubleshooting

### 9.1.1 For LED Indicator

See “**Tab. 7-1 Indicator Stage Description**” for the definition of LED’s status.

Fault Type	Troubleshooting
LED indicator cannot be lit.	<ol style="list-style-type: none"><li>1. Disconnect the AC circuit breaker.</li><li>2. Rotate the optional DC switch to “OFF”.</li><li>3. Check the polarity of DC input.</li></ol>
Green indicator goes out.	<ol style="list-style-type: none"><li>1. Disconnect the AC circuit breaker.</li><li>2. Rotate the optional DC switch to “OFF”.</li><li>3. Check the inverter electrical connection. Refer to “<b>5 Electrical Connection</b>”.</li><li>4. Check whether the voltage of DC input exceeds the inverter start-up voltage.</li><li>5. If all the above conditions are OK, please contact SUNGROW.</li></ol>



Should you have any questions in operating the inverter, please contact us:

Telephone: +86 551 6532 7817.

Email: [service@sungrow.cn](mailto:service@sungrow.cn)

We need the following information to provide you the best assistance:

- Type of the inverter
- Serial number of the inverter
- Fault name (Each fault has a corresponding fault code, for example, 01 represents sampling fault.)
- Brief description of the fault phenomenon

### 9.1.2 For the Faults on the APP or Screen

If the Wi-Fi module or ZE100 (integrated with Wi-Fi function) is equipped, a fault icon will be shown in the APP once a fault occurs. For details, see the related manuals.

If the LCD module eShow is equipped, the “Fault” state will display on the main screen. For details, see eShow User Manual. Follow the procedure below for troubleshooting when the data on the main screen cannot update in real time.

1. Disconnect the external AC circuit breaker.
2. Disconnect the external DC circuit breaker or pull off the DC connectors.
3. Reconnect the breakers or connectors and restart the inverter.
4. If the fault still exists, check whether the communication cable of eShow is firmly connected
5. If the communication cable is firmly connected, contact Sungrow Service Dept.

Fault Code	Description	Troubleshooting
002	The grid voltage exceeds inverter allowable upper limit.	1. Check the voltage of the grid. 2. If the grid voltage exceeds the permissible range of inverter protection parameters, ask utility grid company for solution. 3. If the grid voltage is within the permissible range, contact Sungrow Service Dept.
003	Grid transient voltage exceeds the permissible range	1. This is a short-term fault due to grid condition. Wait a moment for inverter recovery. 2. If the fault still exists, please contact Sungrow Service Dept.
004	The grid voltage is below inverter’s allowable lower limit.	1. Check the grid voltage. 2. If the grid voltage exceeds the permissible range of inverter protection parameters, ask utility grid company for solution. 3. If the grid voltage is within the permissible range, contact Sungrow Service Dept.
005	The grid voltage is too low.	1. This is a short-term fault due to grid condition. Wait a moment for inverter recovery. 2. If the fault still exists, please contact Sungrow Service Dept.
006	The AC output current exceeds inverter allowable upper limit.	1. The inverter will resume if the output current falls below the protection value. 2. If the fault still exists, please contact Sungrow Service Dept.

<b>Fault Code</b>	<b>Description</b>	<b>Troubleshooting</b>
007	Transient overcurrent AC	<ol style="list-style-type: none"> <li>1. The inverter will self-recover after several seconds.</li> <li>2. If the fault still exists, please contact Sungrow Service Dept.</li> </ol>
008	The grid frequency exceeds inverter allowable upper limit.	<ol style="list-style-type: none"> <li>1. Check the grid frequency.</li> <li>2. If the grid frequency exceeds the permissible range of inverter protection parameters, ask utility grid company for solution.</li> </ol>
009	The grid frequency is below the inverter allowable lower limit.	<ol style="list-style-type: none"> <li>3. If the grid frequency is within the permissible range, contact Sungrow Service Dept.</li> </ol>
010	Islanding	<ol style="list-style-type: none"> <li>1. Check whether AC circuit breaker is triggered.</li> <li>2. Check whether AC cables are all firmly connected.</li> <li>3. Check whether grid is not in service.</li> <li>4. If all conditions are OK and this fault still occurs in the LCD screen, contact Sungrow Service Dept.</li> </ol>
011	The DC component of AC current exceeds inverter limit.	<ol style="list-style-type: none"> <li>1. Wait a moment for inverter recovery.</li> <li>2. If the fault occurs repeatedly, contact Sungrow Service Dept.</li> </ol>
012	A failure current is detected.	<ol style="list-style-type: none"> <li>1. Check the PV strings for ground fault.</li> <li>2. If the fault occurs repeatedly, contact Sungrow Service Dept.</li> </ol>
014	The average grid voltage exceeds the permissible range for over 10 minutes.	<ol style="list-style-type: none"> <li>1. Check whether the inverter selected country code is the country you are in.</li> <li>2. Wait a moment for inverter recovery.</li> <li>3. Check the voltage of the grid. If the grid voltage exceeds the permissible range of inverter protection parameters, ask utility grid company for solution.</li> <li>4. If the fault occurs repeatedly, contact Sungrow Service Dept.</li> </ol>
015	The grid voltage exceeds the permissible range	<ol style="list-style-type: none"> <li>1. Check the model of the AC cables.</li> <li>2. Wait a moment for inverter recovery.</li> <li>3. If the grid voltage exceeds the permissible range, ask utility grid company for solution.</li> <li>4. If the fault occurs repeatedly, contact Sungrow Service Dept.</li> </ol>
016	The bus voltage or power is high.	<ol style="list-style-type: none"> <li>1. Wait a moment for inverter recovery.</li> <li>2. If the fault occurs repeatedly, contact Sungrow Service Dept.</li> </ol>

<b>Fault Code</b>	<b>Description</b>	<b>Troubleshooting</b>
019	The transient bus voltage is high.	<ol style="list-style-type: none"> <li>1. Wait a moment for inverter recovery.</li> <li>2. If the fault occurs repeatedly, contact Sungrow Service Dept.</li> </ol>
020	The bus voltage is high.	<ol style="list-style-type: none"> <li>1. Wait a moment for inverter recovery.</li> <li>2. If the fault occurs repeatedly, contact Sungrow Service Dept.</li> </ol>
021	PV1 input overcurrent is detected	Check the layout and the wiring of PV1 input.
022	PV2 input overcurrent is detected	Check the layout and the wiring of PV2 input.
028	PV1 reverse connection fault	Check the cable connections of PV1.
029	PV2 reverse connection fault	Check the cable connections of PV2.
036	The temperature of radiator is too high	<ol style="list-style-type: none"> <li>1. Check whether the ambient temperature shown on the screen is too high. Wait a moment for inverter recovery.</li> <li>2. Check whether there is enough space for convection.</li> <li>3. Check whether the inverter is in direct sunlight.</li> <li>4. Check whether the fan is normal. Replace it if necessary.</li> <li>5. Clean the air inlets.</li> <li>6. If the fault still exists, please contact Sungrow.</li> </ol>
037	The internal temperature of inverter is too high	<ol style="list-style-type: none"> <li>1. Check whether the ambient temperature shown on the screen is too high. Wait a moment for inverter recovery.</li> <li>2. Check whether there is enough space for convection.</li> <li>3. Check whether the inverter is in direct sunlight.</li> <li>4. Check whether the fan is normal. Replace it if necessary.</li> <li>5. Clean the air inlets.</li> <li>6. If the fault still exists, please contact Sungrow.</li> </ol>
038	Relay fault is detected	<ol style="list-style-type: none"> <li>1. Wait a moment for inverter recovery.</li> <li>2. If the fault occurs repeatedly, contact Sungrow Service Dept.</li> </ol>
039	The insulation resistance is low. (ISO-ft)	<ol style="list-style-type: none"> <li>1. Check whether there is a reliable inverter grounding line.</li> <li>2. Check whether the positive and negative of PV panels is short-circuited with ground lead.</li> <li>3. Wait a moment for inverter recovery.</li> <li>4. If the fault occurs repeatedly, contact Sungrow Service Dept.</li> </ol>
041	Leakage current self-test abnormality	<ol style="list-style-type: none"> <li>1. Wait a moment for inverter recovery.</li> <li>2. If the fault occurs repeatedly, contact Sungrow Service Dept.</li> </ol>
043	Ambient temperature is too low, below -30 °C	Shut down and disconnect the inverter. Wait until the ambient temperature rises to the permissible range and restart the inverter.
044	Open-loop inverter self-test fault	<ol style="list-style-type: none"> <li>1. Wait a moment for inverter recovery.</li> <li>2. If the fault occurs repeatedly, contact</li> </ol>

<b>Fault Code</b>	<b>Description</b>	<b>Troubleshooting</b>
045	Faults detected in PV1 boosted circuit	Sungrow Service Dept.
046	Faults detected in PV2 boosted circuit	
048	Sampling channel failure	
053	Auxiliary DSP detects grid voltage exceeds set protection value	<ol style="list-style-type: none"> <li>1. Check the grid voltage.</li> <li>2. If the grid voltage exceeds the permissible range of inverter protection parameters, ask utility grid company for solution.</li> <li>3. If the grid voltage is within the permissible range, contact Sungrow Service Dept.</li> </ol>
054	Auxiliary DSP detects grid frequency exceeds set protection value	<ol style="list-style-type: none"> <li>1. Check the grid frequency.</li> <li>2. If the grid frequency exceeds the permissible range of inverter protection parameters, ask utility grid company for solution.</li> <li>3. If the grid frequency is within the permissible range, contact Sungrow Service Dept.</li> </ol>
056	Auxiliary DSP detects leakage current exceeds set protection range	<ol style="list-style-type: none"> <li>1. Check whether there is a grounded fault of the PV string.</li> <li>2. If the fault occurs repeatedly, contact Sungrow Service Dept.</li> </ol>
061	Alarm for no inverter type setting	Contact Sungrow Service Dept.
070	Fans are defective	Stop the inverter and disconnect the AC & DC cables. Check whether the fan duct has been blocked. If not, replace fans.
074	Communication fault of LCD	<ol style="list-style-type: none"> <li>1. Check whether communication cable of the Eshow is firmly connected.</li> <li>2. If the communication cable is firmly connected, a fault has occurred in the internal communication of the inverter. However, the inverter continues feeding into the grid.</li> <li>3. Contact Sungrow Service Dept.</li> </ol>
100	The AC output current exceeds inverter protection limit.	<ol style="list-style-type: none"> <li>1. The inverter will resume if the output current falls below the protection value.</li> <li>2. If the fault still exists, please contact Sungrow Service Dept.</li> </ol>

Fault Code	Description	Troubleshooting
106	The inverter is not grounded. Neither the PE terminal on the AC connection block nor the second PE terminal on the enclosure is reliably connected.	Check whether there is a reliable inverter grounding line, if there is access to the ground, and the fault still exists, please contact Sungrow Service Dept.
200	The bus voltage is high.	1. Wait for inverter recovery after bus voltage lower. 2. If the fault occurs repeatedly, contact Sungrow Service Dept.
201	The bus voltage is too low.	1. Wait a moment for inverter recovery. 2. If the fault occurs repeatedly, contact Sungrow Service Dept.
202	PV current exceeds the set value of the hardware.	If the fault occurs repeatedly, contact Sungrow Service Dept.
203	DC voltage sampling anomaly.	Check the functionality of the PV connection terminals.
205	AC output relay abnormal	1. Wait a moment for inverter recovery. 2. If the fault occurs repeatedly, contact Sungrow Service Dept.
306	Input and output power mismatching fault	If the fault occurs repeatedly, contact Sungrow Service Dept.
315	PV1 current sampling channel fault	Channel sampling anomaly.
316	PV2 current sampling channel fault	Contact Sungrow Service Dept.
409	Ambient temperature sensor fault and radiator temperature sensor fault	If the fault occurs repeatedly, contact Sungrow Service Dept.
503-506	Temperature sensor warnings	



## 9.2 Routine Maintenance

### DANGER

**Risk of inverter damage or personal injury due to incorrect service!**

**Always keep in mind that the inverter is powered by dual sources: PV array and utility grid.**

**Before any service work, observe the following procedure.**

- **Disconnect the inverter from the utility grid side first and then PV array;**
- **Wait at least 10 minutes for inner capacitors to discharge completely;**
- **Verify that no voltage and current existing with appropriate testing devices.**

### CAUTION

**Keep non-related persons away!**

**A temporary warning sign or barrier must be posted to keep non-related persons away while performing electrical connection and service work.**

### NOTICE

**Risk of inverter damage if it is improperly serviced.**

**Use accessories and spare parts approved by the inverter manufacturer only. Never modify the inverter or other components of the inverter. The loss of any or all warranty rights may follow if otherwise.**

### NOTICE

**Any malfunction that may impair the inverter safety operation must be repaired immediately before the inverter is restarted.**

**Inverter contains no customer serviceable parts inside. Please contact local authorized personnel if any service work is required.**



Servicing of the device in accordance with the manual should never be undertaken in the absence of proper tools, test equipments or the more recent revision of the manual which has been clearly and thoroughly understood.

Items	Methods	Period
System clean	Check the temperature and dust of the inverter. Clean the inverter enclosure. Check the humidity and dust of the environment. Meanwhile check whether the filter function of the air inlet is ok.	Six months to a year (it depends on the dust contents in air.)

# 10 FAQs for SolarInfo Wi-Fi

## 10.1 Cannot Find Wi-Fi Signal of Inverter

If the smart phone cannot find the Wi-Fi signal of inverter after installation, please follow the procedures below for the solutions.



1. Check and ensure that the inverter has been powered on.
2. Check and ensure that the Wi-Fi module has been firmly installed to the corresponding terminal.
3. Your smart phone should not be too far away from the Wi-Fi module. Move them closer to check if the search can be successful.
4. If all the above-mentioned items are ok, yet this problem still exists, it can be verified that the Wi-Fi module has been damaged. Please submit a warranty claim to SUNGROW for replacement.







## 10.2 Too Weak Wi-Fi Signal of Inverter

The Wi-Fi signal strength of inverter is too weak (less than one). Please follow the procedures below for the solutions.

1. Check and ensure that the distance between the inverter bottom and the floor is at least 800 mm.
2. Check and ensure that the Wi-Fi module has been firmly installed to the terminal.
3. Make sure the device is at least 400 mm from the wall.
4. Make sure the device is parallel to the external antenna of the Router.
5. Check and ensure that the Wi-Fi module is not covered by any metal materials.

**Tab. 10-1** Influence to signal strength of different materials or devices

Material	Wireless signal strength	Possible Environment
Wood		Compartment
Plaster\Asbestos		Wall

Material	Wireless signal strength	Possible Environment
Glass		Window
Water		Aquarium, pool, fish tank
Brick wall		-
Marble		Floor
Reinforced concrete		Floor panels, wall
Metal		Iron sheet
cordless smartphones, microwave ovens		-

6. Check and ensure that the installation of inverter and Wi-Fi module has met the requirements, as shown in the following figure.

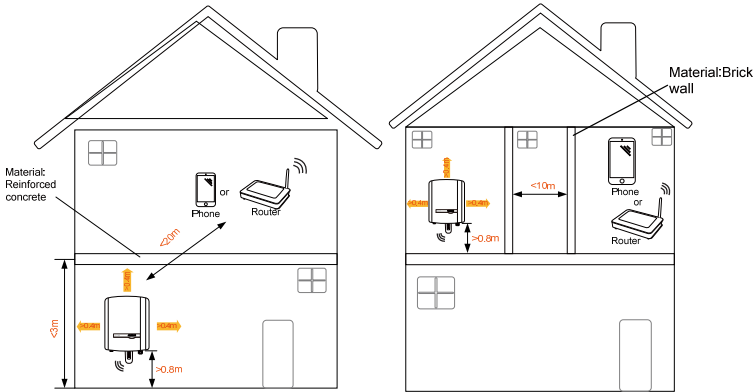
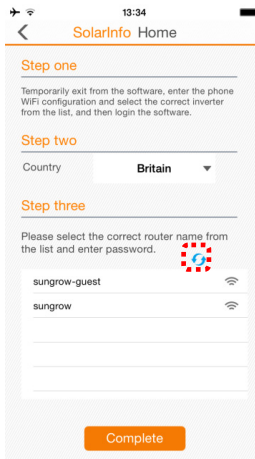

**Fig. 10-1** Installation Requirements of Inverter and Wi-Fi module

## 10.3 Cannot Find Wi-Fi Network of Router

If you cannot find the assigned router in the router list, please follow the procedures below for the solutions.

1. Click the icon on the phone screen to refresh the router list, as shown in the following figure.



**Fig. 10-2** Refreshing the Router List

2. The distance between the router and Wi-Fi module should not be too far. Ensure that there are no metal materials between them.
3. Check and ensure that the router's SSID (Service Set Identifier, hereinafter "SSID") is not named starting with "SG-".
4. Check and ensure that there are no advanced settings of the assigned router.



If you are not sure about any advanced settings, you can reset the router to factory settings.

- The settings of "GUEST WIRELESS SETTINGS" may hide the Router SSID and the Router may not be searched.

**GUEST WIRELESS SETTINGS**

Enable Wireless Guest Network :

Wireless Network Name (SSID) :

Visibility Status :  Visible  Invisible

AP Isolation :  ▼

**Fig. 10-3** Right Setting (Visible)

- Check the setting of router’s max. rate. The Wi-Fi network of router may not be searched when the max. rate is set to 300 Mbps.

## 10.4 Cannot Connect to Wi-Fi Network of Router

The signal strength and other items meet requirements, but the Wi-Fi module of the inverter cannot connect to the Wi-Fi network of the router. Please follow the procedures below for the solutions.

1. Make sure that the router password is correct. Note if there are capital and small letters.
2. If user has changed router SSID or visiting password, please re-connect the inverter Wi-Fi to the Wi-Fi network of the router.
3. The distance between the router and Wi-Fi module should not be too far. Try to move the router closer to the Wi-Fi module and ensure that the distance is within the valid range.
4. Check if the Wi-Fi signal of inverter is too weak. For the solutions, see **“10.2 Too Weak Wi-Fi Signal of Inverter”**.
5. Check and ensure that there are no special characters in router’s SSID, including “+”, “/”, “?”, “%”, “#”, “&”, “=” and “null”.
6. If there is more than one router, their SSIDs should be different. Change the SSIDs if they are the same with each other.
7. Check and ensure that there are no advanced settings of the assigned router.



MAC address filtering, IP range limitation, access number limitation, SSID limitation, DHCP disable may cause connection failure. If you are not sure about any advanced settings, you can reset the router to factory settings.

- “Wireless filter policy” is to set which devices are allowed to be connected to the Router. Do not set this parameter. You may not able to connect to the Router if otherwise.

### WIRELESS FILTER

This page enables users to allow or deny specific wireless devices to connect to the wireless network by specifying the MAC address.

#### WIRELESS FILTER POLICY

You can change the global Wireless Filter Policy here.

Enable Wireless Mac Filtering

Only **DENY** computers listed to access the wireless network.

Only **ALLOW** computers listed to access the wireless network.

### WIRELESS FILTER

Please enter the filter name, such as "My PC", and the MAC address of the wireless interface.

**Filter Name :**

**Wireless MAC Address :**

- Check and ensure that the “Enable DHCP Server” is ticked. Set the “DHCP IP Address Range” as wide as possible, otherwise the accessed user numbers may decrease and the Wi-Fi module of the inverter cannot connect to the Wi-Fi network of the router.

### DHCP SERVER SETTINGS (OPTIONAL)

Use this section to configure the built-in DHCP Server to assign IP addresses to the computers on your network.

**Enable DHCP Server :**

**DHCP IP Address Range :**  to

**DHCP Lease Time :**  (hours)

**DHCP Relay :**

**DHCP Server IP Address :**

Fig. 10-4 DHCP Server Settings

## 10.5 Transmission Signal Strength of Different Materials

The following table shows the wireless signal strength of different transmission materials.

Make sure that there are not materials with poor transmission signal strength between the smart phone and inverter, and the router and the inverter.

See “**Tab. 6-1 Influence to Signal**” for the transmission signal strength of different materials.

## 10.6 Cannot Find Running Data on Server

Although the inverter Wi-Fi is successfully connected to Wi-Fi network of the router, and user has registered to be a user of SolarInfo Bank server, no inverter running data can be viewed.

1. Check and ensure that the router can successfully access to Internet.
2. Check if the firewall is open. Close the Router firewall
3. Check if there is advanced Router configuration. Cancel any advanced configurations.



The advanced settings include MAC address filtering, IP range limitation, access number limitation, SSID limitation, DHCP disable, hidden of the Router SSID and so on. If you are not sure about any advanced settings, you can reset the router to factory settings.

4. If user has registered via [www.solarinfobank.com](http://www.solarinfobank.com) but try to view the running data via the SolarInfo Home APP, the user type should be “**Home Users**”. Otherwise you will fail to login the APP and cannot view any information.



# 11 Appendix

## 11.1 Technical Data

Parameters	SG2KTL-S	SG3KTL-S	SG3KTL-D	SG5KTL-D
<b>Input Side Data</b>				
Max. PV input power	3000W	4000 W	4000 W	6500W
Max. PV input voltage	600 V			
Startup voltage	120 V			
Nominal input voltage	360 V			
MPP voltage range	110...560 V			
MPP voltage range for nominal power	210...480 V	310...480 V	150...480 V	260...480 V
No. of MPPTs	1		2	
Max. number of PV strings per MPPT	1		1	
Max. PV input current (DC1/DC2)	10 A		20 A (10 A/10 A)	
Max. current for input connector	12 A		24 A (12 A/12 A)	
Short-circuit current of PV input (DC1/DC2)	12 A		24 A (12 A/12 A)	
<b>Output Side Data</b>				
Nominal AC output power	2000 W	3000 W	3000 W	5000 W/ 4990 W * (cosΦ=1)
Max. AC output apparent power	2000 VA	3000 VA	3000 VA	5000 VA/ 4990 VA *
Max. AC output current	9.1 A	13.6 A	13.6 A	21.7 A/ 22.7 A *
Nominal AC voltage	220 Vac/230 Vac (Single phase)			
AC voltage range	180...276 Vac (May vary as per corresponding country's grid standard)			
Nominal grid frequency	50 Hz/60 Hz			
Grid frequency range	45...55 Hz/55...65 Hz (May vary as per corresponding country's grid standard)			
THD	<3% (Nominal power)			
DC current injection	<0.5% In			
Power factor	>0.99 @ default value at nominal power (adj. 0.8 over-excited~0.8 under-excited)			

Parameters	SG2KTL-S	SG3KTL-S	SG3KTL-D	SG5KTL-D
<b>Protection</b>				
Anti-islanding protection	Yes			
AC short circuit protection	Yes			
Leakage current protection	Yes			
LVRT	No			
DC reverse connection protection	No			
DC switch	Optional			
DC fuse	No			
Overvoltage protection	Varistors			
<b>System Data</b>				
Max. efficiency	97.4%	97.5%	97.4%	97.5%
Max. European efficiency	96.6%	97.0%	96.9%	97.1%
Isolation method	Transformerless			
Ingress protection rating	IP65			
Night power consumption	<1 W			
Operating ambient temperature range	-25°C...+60°C (> 45°C derating)			
Allowable relative humidity range	0...100%			
Cooling method	Natural cooling			
Max. operating altitude	2000 m			
Display	LED indicator, LCD (optional, see communication options below)			
Communication	Optional: <ul style="list-style-type: none"> <li>• eShow (LCD)</li> <li>• eShow+ (LCD + Wi-Fi)</li> <li>• ZE100 (LCD + Wi-Fi + energy meter for zero-export)</li> <li>• GPRS (for China &amp; Europe)</li> </ul> Remark: Built-in earth fault alarm on eShow, eShow+ and ZE100.			
DC Terminals	MC4			
AC Terminals	Plug and play connector			
Certification	IEC61000-6-2, IEC61000-6-3, AS/NZS3100, AS4777.2, AS4777.3, IEC62109-1, IEC62109-2, VDE-AR-N-4105, VDE0126-1-1, G59/3, G83/2, C10/11, EN50438, NB/T			

Parameters	SG2KTL-S	SG3KTL-S	SG3KTL-D	SG5KTL-D
	32004 ,GB/T29319, KS C8564:2015; CE, CGC, TUV, SAA, KTC			
<b>Mechanical Data</b>				
Dimensions (W x H x D)	300 mm x 370 mm x 125 mm		360 mm x 390 mm x 133 mm	
Mounting method	Wall-mounting bracket			
Weight	9 kg		11 kg	

\* When the country code of SG5KTL-D is set to "AU" (Australia), the nominal output power is 4990 W (VA) and the max. output current is 21.7 A (230 Vac).

## 11.2 Exclusion of Liability

The content of these documents is periodically checked and revised where necessary. Discrepancies therefore may exist. Readers are cautioned that SUNGROW reserves the right to make changes without notice. Please call us or visit our website at [www.sungrowpower.com](http://www.sungrowpower.com) for the latest information. No guarantee is made for the completeness of these documents. Please contact our company or distributors to get the latest version.

Guarantee or liability claims for damage of any kind are excluded if they are caused by one or more of the following:

- improper or inappropriate use or install of the product;
- installing or operate the product in unintended environment;
- installing or operate the product without observing relevant safety regulations in the deployment location;
- ignoring the safety warnings or instructions contained in all documents relevant to the product;
- installing or operate the product under incorrect safety or protection conditions;
- altering the product or supplied software without authority;
- the product faults due to operation attached or neighboring devices beyond of allowed limit values; and
- damage caused by the natural environment beyond the rated operating range of the inverter.

The use of supplied software produced by SUNGROW is subject to the following conditions:

- SUNGROW rejects any liability for direct or indirect damages arising from the use of SolarInfo software. This also applies to the provision or non-provision of support activities.
- Using the SolarInfo software for commercial purposes is prohibited.
- Decompiling, decoding or destroying the original program, including SolarInfo software and the embedded software, is prohibited.

## 11.3 About Us

SUNGROW is a China-leading manufacturer of various power electronics products for renewable energy generation systems, supplying to a global customer base. Our products include converters, inverters, battery chargers and other power supplies for distributable generation systems in both grid-connected and stand-alone applications. The power rating of SUNGROW products covers from several hundred watt to large mega-watt systems.

The vision of Sungrow is to help our customers acquire stable and clean power with minimum cost, maximum reliability and enhanced safety.

### Contact Information

Should you have any problems, please contact us through the following information. We will be more than happy to assist you!

Company:	Sungrow Power Supply Co., Ltd.
Website:	<a href="http://www.sungrowpower.com">www.sungrowpower.com</a>
Email:	<a href="mailto:service@sungrowpower.com">service@sungrowpower.com</a> (China), <a href="mailto:service@sungrow.cn">service@sungrow.cn</a> (Overseas)
Add:	No.1699 Xiyou Rd., New & High Technology Industrial Development Zone, Hefei, P. R. China.
Post Zip:	230088
Service line:	400 880 5578 (China), +86 551 65327834 (Overseas)
Fax:	+86 551 65323478

#### MC Electrical

1/29 Links Avenue N, Eagle Farm, QLD 4009  
 E-Mail: [office@mcelectrical.com.au](mailto:office@mcelectrical.com.au)  
<http://www.mcelectrical.com.au>



**[www.mcelectrical.com.au](http://www.mcelectrical.com.au)**